

# M.479

Bridge handle

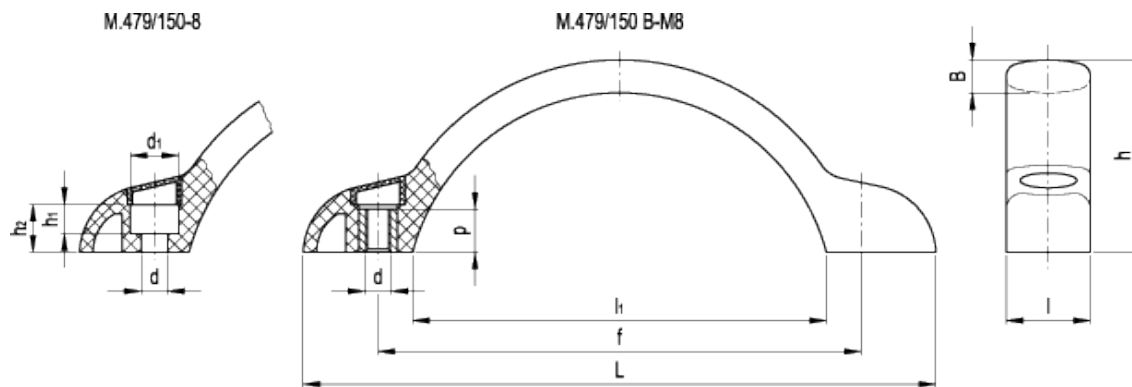

ELESA Original design



## technical informations

### Material

Glass-fibre reinforced polyamide based (PA) technopolymer. Resistant to solvents, oils, greases and other chemical agents.

### Colour

Black, glossy finish.

### Screw covers

Technopolymer in six standard colours, matte finish, press-fit assembly, removable by a screwdriver. Available also as accessories sold separately (see caps table).

### Assembly

M.479/150-8: through holes for cylindrical-head screws with hexagon socket. Screw covers supplied not assembled.  
M.479/150 B-M8: brass boss, tapped holes. Screw covers supplied assembled.

### Technical data

Tensile stress and impact strength: F1, F2, L1 and L2 values reported in the table are the result of breaking tests carried out

with the appropriate dynamometric equipment under the test conditions shown in the figure with ambient temperature.

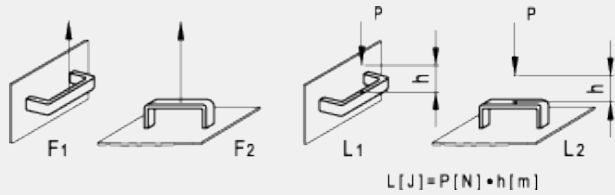

**C1 RAL 7021** **C2 RAL 2004** **C3 RAL 7035** **C4 RAL 1021** **C5 RAL 5024** **C6 RAL 3000**

Standard Elements		Main dimensions						Mounting holes				F <sub>1</sub>	F <sub>2</sub>	L <sub>1</sub>	L <sub>2</sub>	Weight	
Code	Description	L	f	l	h	B	l <sub>1</sub>	d	p	d <sub>1</sub>	h <sub>1</sub>	h <sub>2</sub>	[N]	[N]	[J]	[J]	g
37461-*	M.479/150-8-*	173	132±0.5	23	52.5	9	113	8.5	-	13.5	8.5	13	2100	2600	15	7	49
37466-*	M.479/150 B-M8-*	173	132±0.5	23	52.5	9	113	M8	12	-	-	-	2100	2600	15	7	57

\* Complete the code and the description of the standard item needed by adding the index of the colour of the caps (C1, ..., C6), ex: 37461-C2 M.479/150-8-C2

Code	Description	Caps for
29831-*	ECA.B1-*	M.479/150

\* Complete the code and the description adding the index of the colour (C1, ..., C6).



ELESA models all rights reserved in accordance with the law. Always mention the source when reproducing our drawings.

STANDARD MACHINE ELEMENTS WORLDWIDE